

BIRO

Our Equipment Works Harder So You Don't Have To

The Biro HHP (Heavy Horse Power) Meat Grinders are a series of manual feed grinders with a range of bowl sizes and motor sizes that can be tailored to meet your grinding needs. With bowl sizes of 48, 52, or 56 and motor sizes of 5, 7.5, 10, or 15 hp (4, 5.5, 7.5, or 11 kW), we can provide a grinder that is just right for your operation. All of the HHP series grinders feature single reduction chain drive transmissions for maximum efficiency, and all the grinders use tapered roller bearings for low maintenance and long life. The HHP grinders have output capacities ranging from 1500 lbs. (680 kg) per hour to 7500 lbs. (3400 kg) so you can pick the model that fits best. All across the board, the Biro HHP series of Manual Feed Meat Grinders works harder so you don't have to.

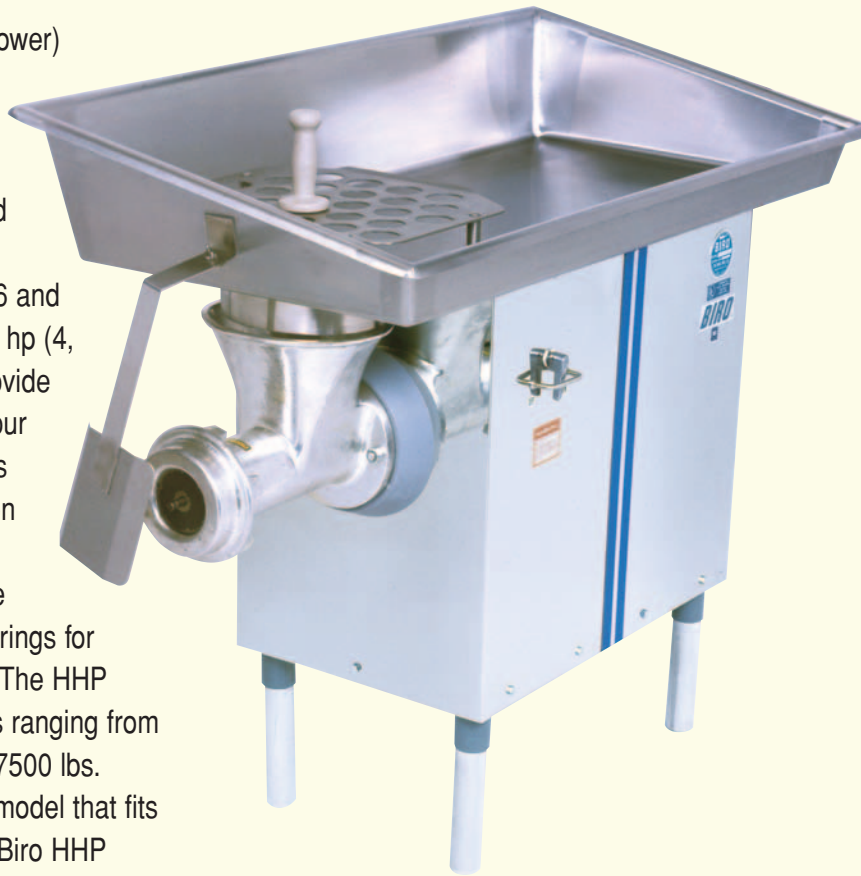

**HEAVY HORSE POWER MANUAL FEED GRINDERS
5, 7.5, 10, 15 HORSE POWER SERIES**



**Stands alone for quality
and value since 1921**

SPECIFICATIONS

MODEL	548SS, 552SS, 7548SS, 7552SS, 1056SS, 1556SS GRINDERS (CHOPPER/MINCER).
CONSTRUCTION	STAINLESS STEEL FEED PAN AND POLISHED STAINLESS STEEL CASE, CAST IRON HOT TIN DIPPED BOWL, RING AND AUGER.
FEED PANS	
ALL MODELS:	FOR 5, 7.5, 10, AND 15 HP UNITS – LEFT-HAND STAINLESS STEEL, HIGH BACK FEED TRAY IS STANDARD. RIGHT-HAND STAINLESS STEEL HIGH BACK FEED TRAYS AVAILABLE ON REQUEST.
CAPACITY FEED PAN	5 & 7.5 HP APPROXIMATELY 100 LBS. (45 KGS.) 10 & 15 HP APPROXIMATELY 115 LBS. (52 KGS.)
GRINDING CAPACITY (APPROXIMATE)	548 & 7548 - 55 LBS. (25 KG) PER MINUTE (1 ST GRIND) & 33 LBS. (15 KG) PER MINUTE (2 ND GRIND). 552 & 7552 - 70 LBS. (32 KG) PER MINUTE (1 ST GRIND) & 40 LBS. (18 KG) PER MINUTE (2 ND GRIND). 1056 & 1556 - 125 LBS. (57 KG) PER MINUTE (1 ST GRIND) & 80 LBS. (36 KG) PER MINUTE (2 ND GRIND).
SWITCH	WATERTIGHT MAGNETIC TYPE WITH THERMAL OVERLOAD AND UNDER VOLTAGE PROTECTION.
POWER CORD	AVAILABLE OPTION AT EXTRA COST.
DRIVE SYSTEM	SILENT (10-15 HP) OR ROLLER LINK (5, 7.5 HP) CHAIN DRIVE OVER WIDE FACE SPROCKETS INSURING MAXIMUM POWER TRANSFER FROM MOTOR TO AUGER.
BEARINGS	DEEP TAPERED ROLLER THRUST BEARINGS CARRY ALL RADIAL AND THRUST LOADS FROM AUGER ELIMINATING FRICTION.
SAFETY	MAGNETIC SAFETY INTERLOCK SO MACHINE WILL NOT OPERATE WHEN FEED PAN WITH WELDED BOWL GUARD IS REMOVED.
STANDARD FEATURES	ALUMINUM LEGS (SEE SCHEMATIC), SPURT GUARD, STOMPER, RING WRENCH, BOWL GUARD ON FEED PAN, OPERATING AND SAFETY MANUAL.
OPTIONS (EC)	SIZE 32 KNIFE AND PLATE, LONGER LEGS ALUMINUM OR STEEL WITH CROSS BRACING, VARIOUS MOTORS (SEE CHART), SOLID STOMPER, CONNECTIONS FOR MIXER-GRINDER SYSTEMS.
CERTIFICATION	U.L., N.S.F., U.S.D.A., C.S.A.

MOTORS

BOWL	HP	KW	VOLTS	AMPS	CYCLE	PH	STATUS
48/52	5	3.7	208-220/440	17-16/8	60	3	STD
48/52	5	3.7	208-230	29-27	60	1	EC
48/52	5	3.7	550-575	6.4-6	60	3	EC
48/52	5	3.7	220/380-415	19.2/11-10	50	3	NC
48/52	7.5	5.6	208-220/440	23-22/11	60	3	STD
48/52	7.5	5.6	550-575	8.8-8.4	60	3	EC
48/52	7.5	5.6	220	26.4	50	3	EC
48/52	7.5	5.6	380-415	15.3-14	50	3	NC
56	10	7.5	208-220/440	27-25.6/12.8	60	3	STD
56	10	7.5	550-575	10-9.6	60	3	EC
56	10	7.5	220/380-415	30.7/17.8-16.3	50	3	NC
56	15	11.2	208-220/440	41-39/19.5	60	3	STD
56	15	11.2	550-575	15.6-14.9	60	3	EC
56	15	11.2	220/380-415	46.8/27-24.8	50	3	NC

ABOVE 3 PHASE MOTORS ALSO AVAILABLE IN 220/380-415-50-3 (NC)

STD=STANDARD 42 BOWL ACCEPTS SIZE 32 PLATES AND KNIVES - EC
 EC=EXTRA COST 48 BOWL ACCEPTS SIZE 32 PLATES AND KNIVES - EC
 NC=NO CHARGE 52 BOWL ACCEPTS SIZE 52 PLATES AND KNIVES - EC
 56 BOWL ACCEPTS SIZE 56 PLATES AND KNIVES - EC

INCH DIMENSION (MM)	548	552	1056
	7548	7552	1556
A	29 (737)	29 (737)	29 (737)
B	52 (1321)	52 (1321)	52 (1321)
C	8 ⁵ / ₈ (219)	8 ⁵ / ₈ (219)	8 ⁵ / ₈ (219)
C'	4 ¹ / ₄ (108)	4 ¹ / ₄ (108)	4 ¹ / ₄ (108)
D	27 ¹ / ₄ (692)	27 ¹ / ₄ (692)	32 ¹ / ₄ (832)
E	2 ³ / ₄ (70)	2 ³ / ₄ (70)	2 ³ / ₄ (70)
F	30 ¹ / ₄ (768)	30 ¹ / ₄ (768)	33 ¹ / ₄ (845)
G	18 ¹⁵ / ₁₆ (481)	18 ¹⁵ / ₁₆ (481)	22 ¹ / ₂ (571)
H	11 (279)	11 (279)	12 ¹ / ₈ (308)
I	4 ¹ / ₄ (108)	4 ¹ / ₄ (108)	4 ¹ / ₂ (114)
J	12 ³ / ₈ (314)	11 ³ / ₄ (298)	16 ³ / ₄ (413)
K	14 ¹ / ₂ (368)	14 ¹ / ₂ (368)	17 ³ / ₄ (451)
L	8 ¹ / ₄ (210)	8 ¹ / ₄ (210)	3 ¹ / ₄ (83)
M	5 (127)	5 (127)	2 ¹ / ₂ (63)
N	17 ¹ / ₂ (444)	17 ¹ / ₄ (438)	21 (533)
O	42 ³ / ₄ (1086)	42 ³ / ₄ (1086)	42 ³ / ₄ (1086)
P	2 ¹ / ₂ (63)	2 ¹ / ₂ (63)	3 ¹ / ₂ (89)
OA	55 (1397)	55 (1397)	58 ³ / ₄ (1492)
APPROX. WT. # PACKED (KG)	510 (232)	520 (236)	705 (320)
APPROX. WT # UNPACKED (KG)	430 (195)	440 (200)	621 (282)

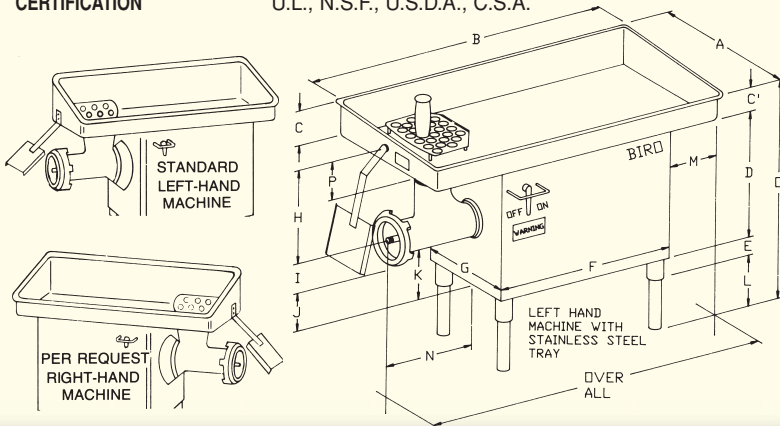

BIRO exclusive non-slip chain drive transmission.

THE BIRO MANUFACTURING COMPANY
 1114 WEST MAIN STREET
 MARBLEHEAD, OH 43440-2099 U.S.A.
 Phone: (419) 798-4451
 Fax: (419) 798-9106
<http://www.birosaw.com>
sales@birosaw.com

ITEM NO.: LIT-HHP-065
 FORM NO.: Md HHP-065-01-07-36 ENG MARK

All specifications contained herein are subject to change without notification.

Service is available from over 245 locations worldwide