



Our Equipment Works Harder So You Don't Have To

With the Biro Model AFMG-56-4 Mixer Grinder you can start increasing the output of your grinding operation without having to spend a fortune to do it. The 400 lb. (182 kg) hopper gives you the kind of capacity you need, and the 15 hp (11.2 kW) auger motor gives you the power you need. The 5 hp (3.7 kW) mixer motor is heavy enough that it won't bog down with a full hopper, and the twin mixing paddles give you a quick, thorough mix. The machine has watertight controls and TEFC motors so you can do a full washdown cleanup. The hopper, frame, paddles, bowl, ring, and auger are all constructed of heavy duty stainless steel so it resists damage and corrosion. As with all Biro designed and built machines, you get the benefit of over 80 years of engineering experience in building meat processing equipment. We know how to build machines that work harder so you don't have to.



AFMG-56-4



*Stands alone for quality
and value since 1921*

SPECIFICATIONS

MODEL AFMG-56-4 MIXER GRINDER.
CONSTRUCTION HEAVY DUTY STAINLESS STEEL HOPPER, LID, PADDLES, FRAME, BOWL, RING AND AUGER, SIZE 56.

MOTORS

MOTOR	HP	KW	TYPE	VOLTS	AUGER	HERTZ	PHASE	CODE
AUGER	15	11.2	TEFC	208-230/460	42-38/19	60	3	STD
MOTOR	5	3.7	TEFC	208-230/460	14-13.2/6.6	60	3	STD
AUGER	15	11.2	TEFC	200	43.7	60	3	EC
MOTOR	5	3.7	TEFC	200	15.4	60	3	EC
AUGER	15	11.2	TEFC	575	15	60	3	EC
MOTOR	5	3.7	TEFC	575	5.2	60	3	EC
AUGER	15	11.2	TEFC	220/380-415	42/24-21.9	50	3	STD
MOTOR	5	3.7	TEFC	220/380-415	14/8.1-7.4	50	3	STD

STD=STANDARD EC=EXTRA COST NC=NO CHARGE
TEFC= TOTALLY ENCLOSED FAN COOLED NA=NOT AVAILABLE

SWITCH WATERTIGHT MAGNETIC WITH THERMAL OVERLOAD AND UNDER VOLTAGE PROTECTION, SEPARATE MIX AND GRIND CONTROLS.

POWER CORD 9' 6-4 CORD.

CAPACITY UP TO 400 LBS. (182 KG).

GRINDING CAPACITY UP TO 200 LBS. (91 KG) PER MINUTE.

DRIVE SYSTEM AUGER: SINGLE REDUCTION EAGLE PD (POLY), SELF-CENTERING, NO STRETCH, NO LUBRICATING DRIVE BELT. MIXER: DOUBLE REDUCTION GEAR BOX AND OPEN FACE GEAR DRIVE.

SAFETY MAGNETIC SAFETY INTERLOCK ON LID.

STANDARD FEATURES NO INLET (SOLID TUB) HOPPER, GAS CYLINDER TO ASSIST LID OPENING, SPURT GUARD, RING WRENCH, OPERATING AND SAFETY MANUAL.

OPTIONS (EC) ELECTRICAL OR PNEUMATIC FOOTSWITCH, SIZE 56 KNIFE AND PLATE, CAST IRON HOT TIN-DIPPED BOWL, RING AND AUGER, ROD STYLE GRATED LID FOR CONTINUOUS FEED, LOCKING SWIVEL CASTERS, 90° STRAIGHT RIGHT OR LEFT INLET WITH CONNECTIONS FOR TANDEM OPERATIONS, CASTERS.

OPTIONS (NC) NA

CERTIFICATION NA

WEIGHT UNCRATED: 1760 LBS. (798 KG) APPROXIMATE.
CRATED: 2060 LBS. (934.4 LG) APPROXIMATE.

DIMENSIONS CRATED L=67" (1701 MM), W=48" (1219 MM), H=76" (1930 MM)

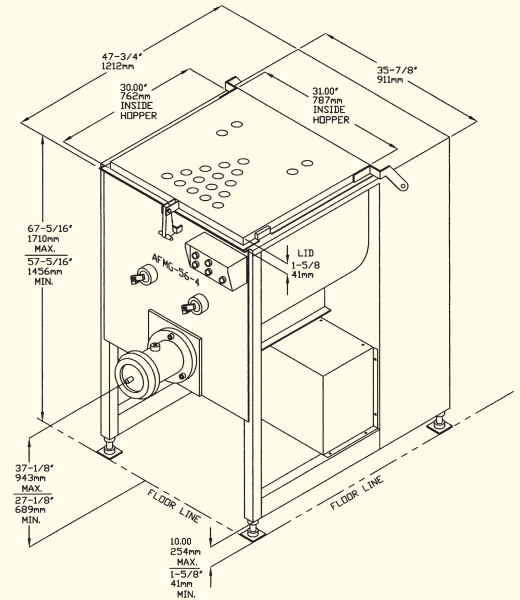

DIMENSIONS

MACHINE HEIGHT 57-5/16" (1456 MM) MIN.
67-5/16" (1710 MM) MAX.

MACHINE HEIGHT (WITH LID UP) 90-7/8" (2308 MM) MIN.
99-7/8" (2537 MM) MAX.

BOWL HEIGHT 27-7/8" (708 MM) MIN.
36-7/8" (937 MM) MAX.

LENGTH 50" (1270 MM)

LENGTH (FROM END OF KNIFE DRIVE PIN) 59-5/16" (1507 MM)

WIDTH 35-7/8" (911 MM)

THE BIRO MANUFACTURING COMPANY
1114 WEST MAIN STREET
MARBLEHEAD, OH 43440-2099 U.S.A.
Phone: (419) 798-4451
Fax: (419) 798-9106
<http://www.birosaw.com>
sales@birosaw.com

ALL SPECIFICATIONS CONTAINED HEREIN ARE SUBJECT TO CHANGE WITHOUT NOTIFICATION.

ITEM NO.: LIT-AFMG-56-4-329
FORM NO.: Md AFMG-56-4-329-10-06-2-ENG-MARK

Service is available from over 245 locations worldwide