

BIRO®

Our Equipment Works Harder So You Don't Have To

The Biro 6642 Meat Grinder is a versatile manual feed grinder that can be used as either a compact floor grinder or a large countertop grinder. Its 2 HP motor has plenty of power, and the size 42 head and wide angle bowl ensure good productivity. The 6642's compact size means it can fit into tight places, which makes it ideal for meat shops, small grocery store meat rooms, and commercial or institutional kitchens. The exclusive Biro oil bath type transmission with double reduction steel gears ensures quiet, trouble-free operation for many years.

The bowl assembly and feed tray are easily removed without tools, so cleanup is a snap. Quiet and easy operation, durability, and low maintenance all help make the Biro 6642 Meat Grinder work harder so you don't have to.



6642



*Stands alone for quality
and value since 1921*

SPECIFICATIONS

MODEL 6642 GRINDER (CHOPPER, MINCER).
CONSTRUCTION STAINLESS STEEL FEED PAN AND POLISHED STAINLESS STEEL CASE,
 CAST IRON HOT TIN DIPPED BOWL, RING AND AUGER, SIZE 32.

MOTORS

HP	TYPE	KW	VOLTS	AMPS	HERTZ	PHASE	CODE
2	ODP	1.5	208-220/440	6.4-6/3.6	60	3	STD
2	ODP	1.5	115/208-230	28/15-14	60	1	STD
2	ODP	1.5	104/208	31/15.5	60	1	NC
2	ODP	1.5	208/416	6.4/3.2	50	3	NC
2	ODP	1.5	115/230	30/15	50	1	NC
2	ODP	1.5	220/380-415	6/3.5-3.1	50	3	NC

ODP=OPEN DRIP PROOF STD=STANDARD NC=NO CHARGE
 EC=EXTRA CHARGE NA=NOT AVAILABLE

SWITCH MAGNETIC CONTACTOR WITH WATERPROOF PUSH BUTTONS MOUNTED
 ON RIGHT SIDE OF MACHINE WHEN FACING BOWL AND FEED PAN
 INTERLOCK. PUSH BUTTONS CAN BE OPTIONALLY MOUNTED
 EITHER LEFT OR RIGHT OF THE STAINLESS STEEL CASE.

POWER CORD AVAILABLE OPTION AT EXTRA COST.

CAPACITY FEED PAN APPROXIMATELY 75 LBS. (34 KG).

GRINDING CAPACITY UP TO 41 LBS. (18.5 KG) PER MINUTE, 1/8" PLATE FIRST GRIND.

DRIVE SYSTEM DIRECT DRIVE OIL BATH TRANSMISSION AND DOUBLE REDUCTION
 STEEL GEARS, TAPERED ROLLER BEARINGS.

SAFETY MAGNETIC INTERLOCK SO MACHINE WILL NOT OPERATE WHEN FEED PAN
 WITH WELDED BOWL GUARD IS REMOVED.

STANDARD FEATURES 4" ALUMINUM LEGS, SPURT GUARD, STOMPER, RING WRENCH, BOWL GUARD
 ON FEED PAN, OPERATING AND SAFETY MANUAL.

OPTIONS (EC) SIZE 32 KNIFE AND PLATE, POWER CORD AND PLUG, LONGER LEGS.

OPTIONS (NC) NA

CERTIFICATION U.L., N.S.F., U.S.D.A., C.S.A.

WEIGHT
 1 PHASE UNCRATED: 243 LBS. (110 KG) APPROXIMATE.
 1 PHASE CRATED: 278 LBS. (126 KG) APPROXIMATE.
 3 PHASE UNCRATED: 222 LBS. (101 KG) APPROXIMATE.
 3 PHASE CRATED: 270 LBS. (122 KG) APPROXIMATE.

DIMENSIONS CRATED L = 25" (635 MM), W = 45" (1143 MM), H = 30" (762 MM).

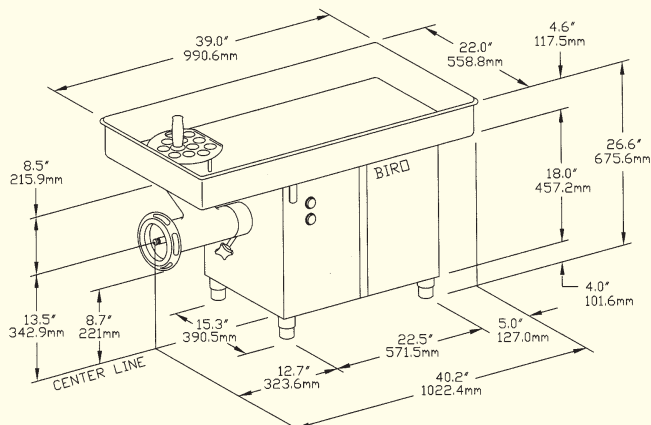
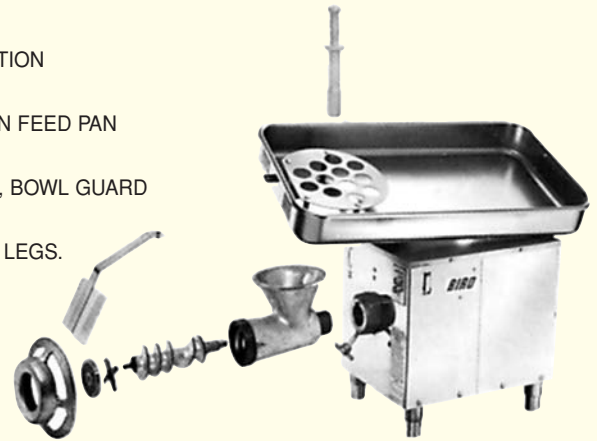

THE BIRO MANUFACTURING COMPANY
 1114 WEST MAIN STREET
 MARBLEHEAD, OH 43440-2099 U.S.A.
 Phone: (419) 798-4451
 Fax: (419) 798-9106
<http://www.birosaw.com>
sales@birosaw.com

ALL SPECIFICATIONS CONTAINED HEREIN ARE SUBJECT TO CHANGE WITHOUT NOTIFICATION.

ITEM NO.: LIT 6642-179

FORM NO.: Md 6642-10-06-14-ENG-MARK

Service is available from over 245 locations worldwide