

BIRO

Our Equipment Works Harder So You Don't Have To

Biro's Model 11, 10" Power Cutter is equipped with a 1½ HP motor and toggle switch as standard. A powder coated steel base, with aluminum head and door structures are standard. The removable platter and meat carriage are stainless steel.

Designed for use in small delis, meat shops, small grocery stores and restaurants. Excellent for boneless meats, chicken and pork chop cutting.

Proven design concepts with the durability and reliability found on other Biro Power Cutters. Strong load bearing components. Biro's single flange wheel concepts protect the blades set and teeth. Disassembles for easy cleaning without tools and is economical to use.



11



**Stands alone for quality
and value since 1921**

SPECIFICATIONS

MODEL
CONSTRUCTION
MOTORS

11 POWER CUTTER (10").
STEEL PLATE POWDER COATED BASE, ALUMINUM HEAD.

HP	KW	TYPE	VOLTS	AMPS	CYCLE	PH	STATUS
1 1/2	1.1	HH	115/208-230	21/11/10.5	60	1	STD
1 1/2	1.1	HH	208-220/440	5.6/2.8	60	3	STD
1 1/2	1.1	HH	115/208-230	20.2/10.1	50	1	EC
1 1/2	1.1	TE	115/208-230	16/8	60	1	EC
1 1/2	1.1	TE	208-220/440	5.6/2.8	60	3	EC
1 1/2	1.1	HH	380/415	3.6/3.24	50	3	STD
1 1/2	1.1	TE	380/415	3.6/3.24	50	3	EC

TE= TOTALLY ENCLOSED STD=STANDARD
HH= HIGH HUMIDITY EC=EXTRA COST

STANDARD FEATURES

ONE SAW BLADE, OPERATION AND SAFETY MANUAL, SAFETY WALL POSTER, END CUT SAFETY PUSHER PLATE.

SWITCH

TOGGLE, STANDARD, 2 HP RATED, PLACED CONVENIENTLY IN FRONT.

HEAD AND DOOR

ALUMINUM, ENTIRE ASSEMBLY REMOVABLE.

BASE STRUCTURE

STEEL PLATE, WELDED POWDER COATED.

BLADE STANDARD

HARD TOOTH .020 INCH (.4 MM) THICK, FOUR TEETH PER INCH, 5/8 INCH (16 MM) WIDE, 78" (1981 MM) LONG, ONE SUPPLIED WITH EACH SAW.

BLADE SPEED

3000 FEET (914 M) PER MINUTE APPROXIMATE, FOR BOTH 50 AND 60 CYCLE OPERATION.

BLADE GUIDE

UPPER AND LOWER BLADE BACKUP GUIDE ASSEMBLIES, REMOVABLE WITH LONG LIFE CARBIDE BACKUP INSERTS.

BLADE TENSION

RATCHET ARM AND CAM AGAINST POUND TESTED SPRING AND TENSION SPRING GAUGE.

BLADE WHEELS

10" (25.4 CM) CAST IRON, CHROME NICKEL PLATING, UPPER WHEEL ASSEMBLY LIFTS OUT.

BEARINGS

HEAVY DUTY TAPERED ROLLER BEARINGS IN UPPER WHEEL AND LOWER BEARING HOUSINGS.

CATCH PAN

POLY, EXTRA DEEP, ROUNDED CORNERS, SEALED OFF FROM OTHER PARTS OF BASE, ACCESSIBLE THROUGH BASE HINGED DOOR.

CLEANING UNIT

LONG LIFE CARBIDE GUIDES, STEEL SAW CLEANERS, REMOVABLE AS A UNIT FOR EASY CLEANING, (ASSEMBLY ALSO ADJUSTABLE AS A UNIT).

DRIVE SYSTEM

NON-SLIP SILENT V-BELT, TENSION ADJUSTABLE.

LEGS

STRAIGHT, NON ADJUSTABLE.

MEAT CARRIAGE

STAINLESS STEEL WITH NYLON GUIDES AND STEEL BEARINGS.

MEAT GAUGE PLATE

STAINLESS STEEL FACED, ADJUSTABLE FROM 1/16" (1.59 MM) TO 6-1/2" (165 MM), LOCKS IN POSITION, CAN BE THROWN OUT OF GEAR, ENTIRE ASSEMBLY REMOVABLE FOR CLEANING.

MOTOR COMPARTMENT

SEALED OFF FROM MEAT CONTACT AREAS, EASILY ACCESSIBLE THROUGH REMOVABLE PANEL DOOR.

PLATTER

ALL STAINLESS STEEL, HELD IN PLACE WITH TWO PUSH PULL HOLD DOWN STAINLESS STEEL RODS.

SAFETY END CUT

PUSHER PLATE

STANDARD, REMOVABLE.

OPTIONS (EC)

POWER CORD AND PLUG, TOTALLY ENCLOSED MOTOR, WATERTIGHT MAGNETIC SWITCH WITH THERMAL OVERLOAD AND UNDER VOLTAGE PROTECTION, NSF CERTIFICATION.

CERTIFICATION

C.S.A., U.L. NOTE: IF NSF IS REQUIRED, MUST SPECIFY, EXTRA COST FOR NSF REQUIREMENTS.

WEIGHT

UNCRATED: 256 LBS. (116 KG) APPROXIMATE.
CRATED: 298 LBS. (135 KG) APPROXIMATE.

DIMENSIONS

CRATED

L = 32" (81.3 CM), W = 40" (101.6 CM), H = 38-1/2" (97.8 CM).

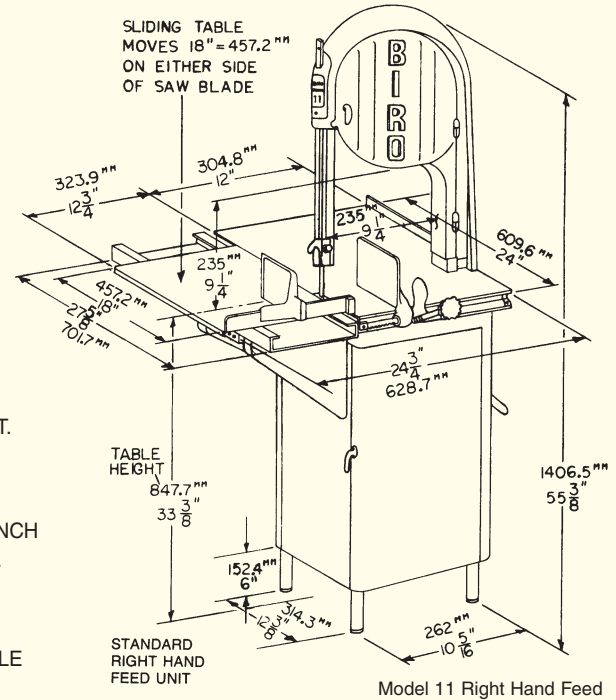

Model 11 Right Hand Feed

THE BIRO MANUFACTURING COMPANY
1114 WEST MAIN STREET
MARBLEHEAD, OH 43440-2099 U.S.A.
Phone: (419) 798-4451
Fax: (419) 798-9106
<http://www.birosaw.com>
sales@birosaw.com

ITEM NO.: LIT 11-007
FORM NO.: Md 11-007-6-06-37-MARK

Service is available from over 245 locations worldwide