



Known for Reliability Since 1921

**NEW
FIXED HEAD!**



The BIRO Model 44SSFH (Stainless Steel/Fixed Head) Power Meat Saw equipped with a **(142" (3606.8mm) Saw Blade)** is a heavy-duty, high-volume bandsaw that is well-suited for continuous intensive operation. The 3HP industrial motor, at 4000 feet per minute as standard blade speed, provides you with plenty of power and efficiency. BIRO's EZ-Flow meat carriage with 8 Stainless Steel Bearings helps reduce operator fatigue and increase productivity. The watertight magnetic electrical controller helps ensure safe, reliable operation. The 18" diameter saw blade wheels with a 17-1/8" (435 mm) horizontal cutting clearance and a full 17" (431.8mm) vertical cutting clearance lets you cut larger product pieces than other saws. A broad range of designs, configurations, and options give you the flexibility to own a saw that fits your exact needs. The BIRO Model 44 Series Power Meat Saws have superior durability and engineering features you've come to expect from BIRO, which means you'll get years of reliable use, low maintenance, and minimal overall cost of ownership.

44SSFH

Model 44SSFH (Stainless Steel Fixed Head) Power Meat Saw, 142" (3606.8mm) Saw blade

MODEL 44SSFH SPECIFICATIONS

Model: 44SSFH (Stainless Steel/ Fixed Head)
Power Meat Cutter 18" (457mm) Saw Blade Wheels

Motors:

HP	TYPE	VOLTS	AMPS	CYCLE	PH	STATUS
3	DP	208-220/440	10.5-9.6/4.8	60	3	STD
3	TE	208-230	15.4-14	60	1	EC
3	TE	110/220	6.25/12.5	50	1	EC
5	MR	208-220/440	17-16/8	60	3	EC
5	MR	575	5.9	60	3	EC
5	MR	220/380-415	16/9.3-8.5	50	3	EC

DP = Drip Proof TE = Totally Enclosed
MR = Moisture Resistant STD = Standard EC = Extra Cost

Construction: Stainless steel.

Standard Features: Two saw blades, operation and parts manual, safety wall poster, end cut safety pusher plate.

Switch: Watertight magnetic with thermal overload and under voltage protection.

Head and Door: Stainless steel fixed head, removable head door.

Blade Standard: Hard tooth, three teeth per inch (8.5 mm between teeth), 142" (3606.8 mm) long x 5/8" (16 mm) wide, .022" (.56 mm) thick (two supplied with each saw).

Blade Speed: Std. 4000 feet (1219 m) per minute approx.

Blade Back-up Guides: Upper and lower blade backup guide assemblies, removable, with long life carbide back-up inserts.

Blade Tension: Factory preset spring with screw handle assembly.

Blade Wheels: 18" (457 mm) cast iron, chrome nickel plating, upper wheel assembly lifts out.

Bearings: Heavy duty tapered roller bearings used in upper wheel and lower bearing housings.

Catch Pan: Poly, extra deep (rounded corners) pan sealed off from other parts of base, accessible through base hinged door.

Cleaning Unit: Stainless steel body, long life carbide guide insert, stainless steel saw cleaners, removable as a unit for easy cleaning (assembly also adjustable as a unit).

Drive System: Non slip silent v-belt, tension adjustable.

Legs: Four stainless steel leg bolt levelers.

Meat Carriage: Stainless steel EZ-flow movement with eight stainless steel bearings.

Meat Gauge Plate: Stainless steel faced, adjustable from 1/16" (1.59 mm) to 6-1/2" (165 mm) locks in position, can be disengaged, entire assembly removable for cleaning.

Motor Compartment: Sealed off from meat contact areas, easily accessible through removable panel door.

Rear Platter: All stainless steel, held in place with two push pull hold down stainless steel rods.

Safety End Cut Pusher Plate: Standard, removable, pusher plate storage hanger provided.

Options (EC): Power cord and plug, stationary front table, double saw guide bar, low profile head, 1" wide saw blade system, *double moving carriage, *roller tops, double flange cast blade wheels, narrow guides for .018"/0.46 mm thick blade, *split (2 pc) rear stationary platter, longer meat gauge plates, meat gauge plate stabilizer, stainless steel single flange cast blade wheels. * Note: All above table modifications are for 44SSFH right to left feed saw only.

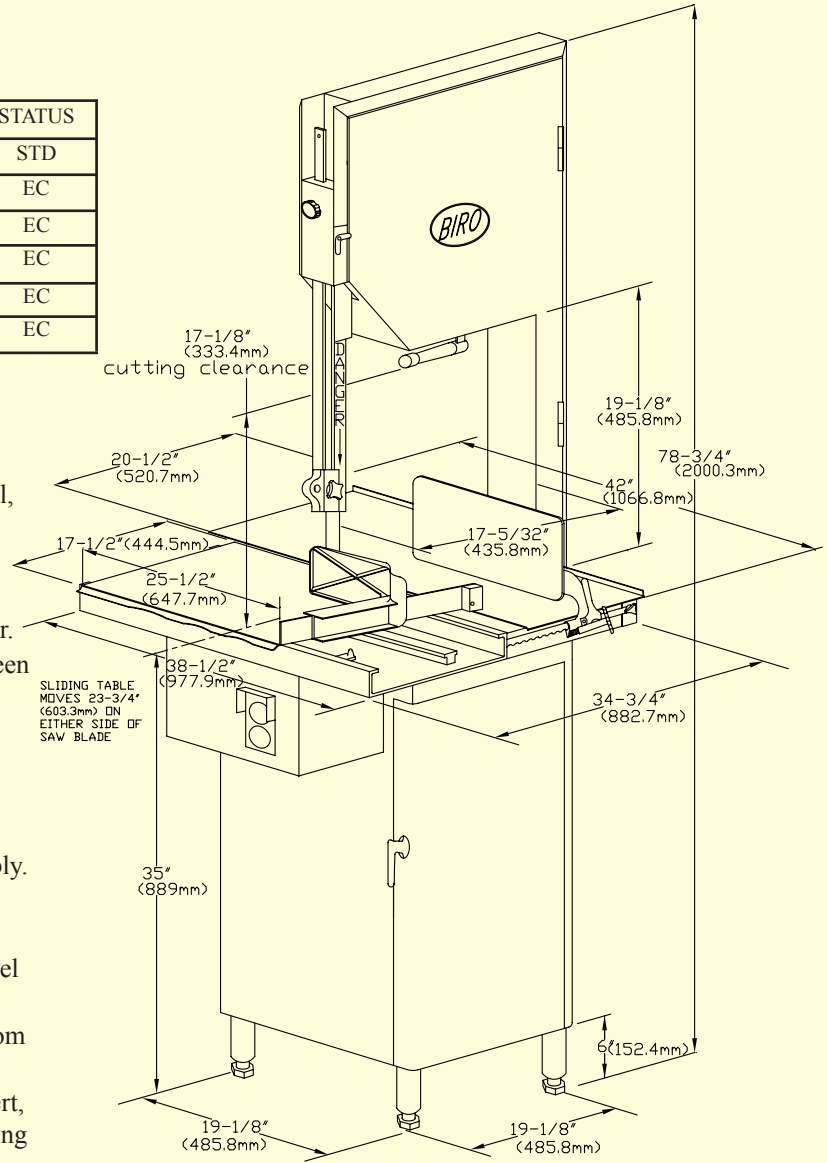

MODEL 44SSFH CONFIGURATION
142" (3606.8 mm) SAW BLADE

Certification: U.S.D.A., U.L., N.S.F., C.F.I.A.
(C.S.A., STD., DP, 3HP-230-60-3)

Weight: Uncrated: 600 lbs. (272 kg.) approximate.
Crated: 700 lbs (318 kg.) approximate.

Dims. Crated: L = 54" (137 cm), W = 45" (114 cm),
H = 83" (211 cm).

THE BIRO MANUFACTURING COMPANY

1114 WEST MAIN STREET

MARBLEHEAD, OH 43440-2099 U.S.A.

Phone: (419) 798-4451

<http://www.birosaw.com>

Fax: (419)798-9106

sales@birosaw.com

ITEM NO.: LIT-44SSFH-369

FORM NO.: 44SSFH-369-9-13-1-B

All specifications contained herein are subject to change without notification.

Service is available from locations worldwide