



Known for Reliability Since 1921

The Biro Model AFMG-48 is a workhorse mixer grinder for the medium volume meat operation. Its 7.5 hp (5.6 kw) auger motor and size 32 head can give an output of over 65 pounds (30 kg) per minute for the productivity you need. Separate auger and mixer motors mean there is no clutch to wear out or break, which means much lower maintenance costs and higher profits. The single reduction heavy duty roller chain auger drive with tapered roller bearings is the most efficient drive system, so you get maximum power to the auger. The heavy duty stainless steel 200 pound (91 kg) hopper, frame, and legs can stand up to years of daily washdown and still resist corrosion, so your mixer grinder lasts longer and you get a better return on your investment. Power, durability, and low maintenance.



AFMG-48



**Stands alone for quality
and value since 1921**

SPECIFICATIONS

MODEL AFMG-48 MIXER GRINDER.
CONSTRUCTION HEAVY DUTY STAINLESS STEEL HOPPER, LID, PADDLE, FRAME AND LEGS.
CAST IRON HOT TIN DIPPED BOWL, RING AND AUGER, SIZE 32.

MOTORS

MOTOR	HP	KW	TYPE	VOLTS	AMPS	CYCLE	PH	STATUS
AUGER	7.5	5.5	TEFC	208-230/460	24-21/11	60	3	STD
MIXER	1.75	1.3	TEFC	208-230/460	5.7-5.5/2.6	60	3	STD
AUGER	10	7.5	TEFC	208-230/460	31-27/14	60	3	EC
AUGER	7.5	5.5	TEFC	575	8.8	60	3	EC
MIXER	1.75	1.3	TEFC	575	2.4	60	3	EC
AUGER	10	7.5	TEFC	575	11	60	3	EC
AUGER	7.5	5.5	TEFC	220/380-415	22/12.7-12.4	50	3	STD
MIXER	1.75	1.3	TEFC	220/380-415	5.9/3.4-3.1	50	3	STD
AUGER	10	7.5	TEFC	220/380-415	28/16.2-14	50	3	EC

TEFC= TOTALLY ENCLOSED FAN COOLED STD=STANDARD
EC=EXTRA COST NC=NO CHARGE

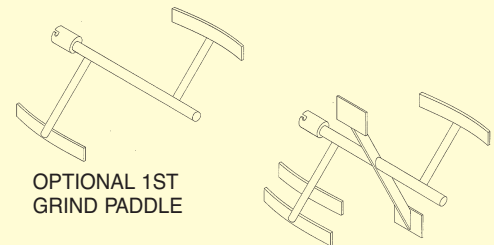

OPTIONAL 1ST GRIND PADDLE

STANDARD PADDLE

SWITCH WATERTIGHT MAGNETIC WITH THERMAL OVERLOAD AND UNDER VOLTAGE PROTECTION.

POWER CORD 12' 10-4 CORD WITH PLUG 7-1/2 HP, U.S., 12' 10-4 CORD NO PLUG 7-1/2 HP, 50 HZ AND 575 VOLT.
12' 8-4 CORD WITH PLUG 10 HP U.S., 12' 8-4 CORD NO PLUG 10 HP, 50 HZ AND 575 VOLT.

HOPPER CAPACITY HOPPER 200 LBS. (91 KG).

GRINDING CAPACITY OUTPUT – UP TO 65 LBS. (30 KG) PER MINUTE.

DRIVE SYSTEM AUGER: SINGLE REDUCTION (35 PITCH – 4 ROW)
ROLLER CHAIN DRIVE WITH TAPERED ROLLER BEARINGS.
MIXER: HEAVY DUTY COMBINATION GEAR MOTOR.

SAFETY MAGNETIC SAFETY INTERLOCK ON HOPPER LID.

STANDARD FEATURES NO INLET (SOLID TUB) HOPPER, STAINLESS STEEL 2ND GRIND PADDLE WITH CENTER ARMS, CASTERS, SPURT GUARD, EXTRA ROD FOR FRONT, LEFT OR RIGHT SIDE OPENING LID, POWER CORD (SEE ABOVE), RING WRENCH, BOWL NUT WRENCH, TWO SHEAR PINS WITH SCREWS, RECEPTACLE FOR ELECTRIC FOOTSWITCH, OPERATING AND SAFETY MANUAL.

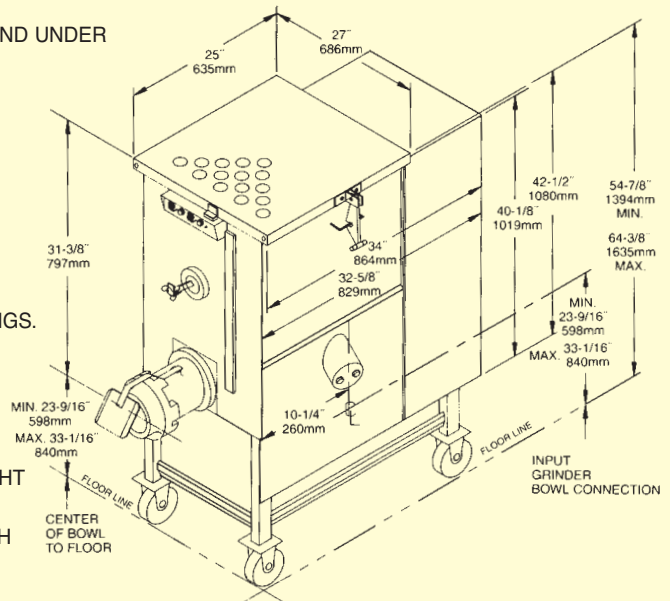

OPTIONS (EC) ELECTRICAL OR PNEUMATIC FOOTSWITCH, SIZE 32 KNIVES AND PLATES, ACCESSORY CLEANING AND STORAGE RACK, EXTRA LONG STAINLESS STEEL LEGS (33"/838 MM TO 44"/1069 MM) FROM FLOOR TO BOWL CENTER, LEFT HAND 35 DEGREE SIDE INLET, LEFT OR RIGHT 90 DEGREE STRAIGHT SIDE INLET, CONNECTIONS FOR TANDEM OPERATIONS, 10 HP (7.5 KW) AUGER MOTOR, STAINLESS STEEL BOWL, RING AND AUGER (ENTERPRISE OR UNGER).

OPTIONS (NC) TUB WITH 35 DEGREE RIGHT HAND INLET (CALL FACTORY).

CERTIFICATION U.S.D.A., U.L., N.S.F., C.S.A. ON 7-1/2 208/230/460-60-3

WEIGHT UNCRATED: 720 LBS. (327 KG) APPROXIMATE.

CRATED: 830 LBS. (377 KG) APPROXIMATE.

DIMENSIONS CRATED L = 52" (130 CM), W = 35" (89 CM), H = 64" (163 CM).

THE BIRO MANUFACTURING COMPANY
1114 WEST MAIN STREET

MARBLEHEAD, OH 43440-2099 U.S.A.

Phone: (419) 798-4451

Fax: (419) 798-9106

<http://www.birosaw.com>

sales@birosaw.com

ALL SPECIFICATIONS CONTAINED HEREIN ARE SUBJECT TO CHANGE WITHOUT NOTIFICATION.

ITEM NO.: LIT-AFMG48-123
FORM NO.: Md AFMG48-8-10-7-ENG-MARK

Service is available from over 245 locations worldwide